

# Mission 1K-2K-3K

Single Phase UPS

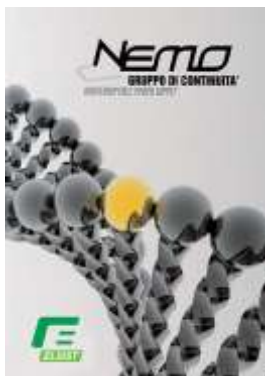

Uninterruptible Power Systems

## Contents

<b>1.Safety instruction</b> .....	<b>3</b>
1.1 Safety instruction.....	3
1.2 Symbols indication .....	3
<b>2.Product Introduction</b> .....	<b>4</b>
2.1 The appearance of the product.....	4
2.2 The principle of the product.....	5
2.3 Model.....	5
<b>3.Installation</b> .....	<b>6</b>
3.1 Unpacking and inspection .....	6
3.2 Notes .....	6
3.3 UPS input connection.....	6
3.4 UPS output connection .....	6
3.5 Long backup external battery connection .....	7
<b>4.Panel display,operation and running</b> .....	<b>8</b>
4.1 Faceplate display illumination .....	8
4.2 Operation.....	10
4.3 Parameter setting.....	11
4.4 Parameters inquiring.....	17
4.5 Run mode.....	18
<b>5.Maintenance</b> .....	<b>20</b>
5.1 Battery Maintenance .....	20
<b>6.Troubleshooting and performance of product</b> .....	<b>20</b>
6.1 LED indication and warning table .....	21
6.2 Troubleshooting.....	22
6.3 EMC standard/Safety standard.....	23
6.4 Product Performance .....	23
6.5 Communication interface .....	25

### Manual instruction

Thanks for purchasing our UPS, it is safe and reliable, so few maintenance is required.

Read this manual carefully and completely. It includes instructions of safety installation and operation. They will help your UPS obtain the longest life and service. This manual accounts the internal working principle and the relative protection functions. This manual also contains information about the usage of the equipment.

Please obey the instructions and all the warning stated in the manual or on the machine. Don't operate the machine before finishing reading the safety and operation instructions.

Note: Because of the continuous improvements, our products may differ somewhat from the contents included in this manual. You can contact local office to get the information when necessary.

# 1. SAFETY INSTRUCTION

This chapter mainly introduce the safety marks and notes of MISSION 1KVA-2KVA-3KVA series on-line UPS. Read this chapter carefully before operating on the equipment.

## 1.1 Safety instruction

There is dangerous voltage and high temperature inside the UPS. During the installation, operation and maintenance, please abide the local safety instructions and relative laws, otherwise it will result in personnel injury or equipment damage. Safety instructions in this manual act as a supplementary for the local safety instructions.

Our company will not assume the liability that caused by disobey of safety instructions. Please note the following:

1. Don't use the UPS when the actual load exceeds the rated load.
2. There are high-capacity batteries in the standard type UPS. You mustn't open the enclosure or it will lead to electric shock. If it needs internal maintenance or battery replacement, please send it to the designated site.
3. Internal short-circuit of the UPS will cause electric shock or fire. So don't place the containers equipped with liquid on the top of the UPS so as not to cause danger of electric shock and so on.
4. Don't put the UPS in a place with high temperature or humidity as well as the corrosive gas, much dust.
5. Keep good air circulation between in-vent on front panel and out-vent on back panel.
6. Avoid direct sunlight or near heat-dispensed objects.
7. In case that the smoke appears on the UPS, please cut off the power as soon as possible and contact the dealer service site.

## 1.2 Symbols indication

The safety symbols cited in this manual are shown in table 1-1, which are used to inform readers of safety issues that should be obeyed when installation, operation and maintenance.



Safety Symbol	Indication
	Attention
	Static discharge sensitive
	Electric shock

Table 1-1

There are three levers of safety grade: Dangerous, Warning and Attention. The remark is on the right side of the safety symbol, the detailed comments is behind, shown as following:



**Dangerous:** Indicate risk of serious injury or death or seriously damage the equipment



**Warning:** Indicate risk of serious injury or damage the equipment.



**Attention:** Indicate risk of injury or damage the equipment.

## 2. PRODUCT INTRODUCTION

### 2.1 The appearance of the product

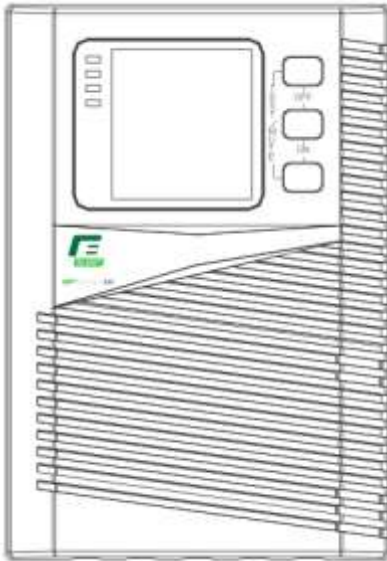

Fig. 1 Front Panel view

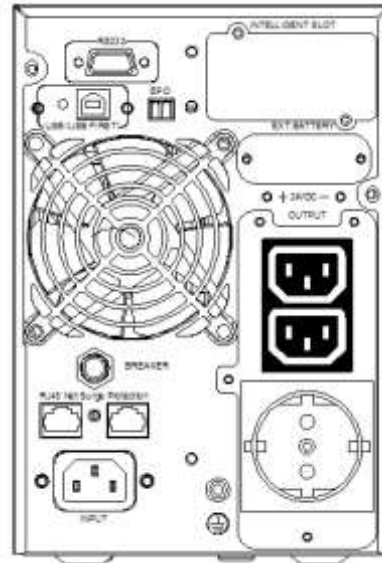

Fig. 2 1KVA Rear Panel view

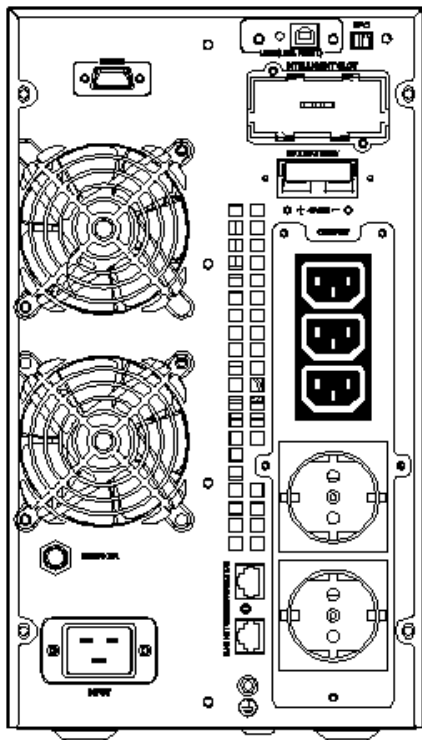

Fig. 3 2KVA Rear Panel view

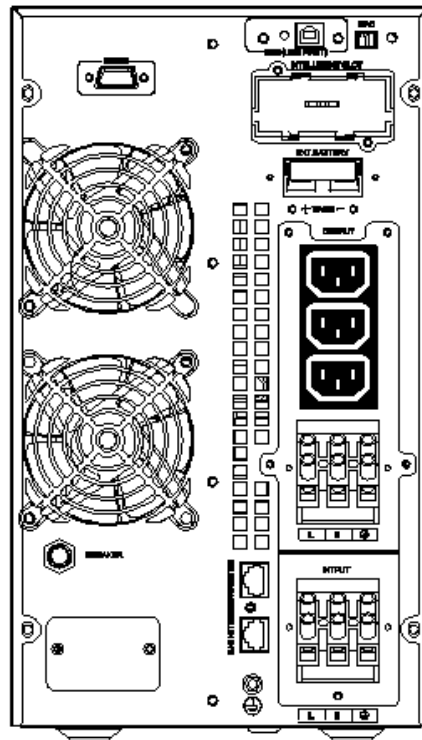

Fig. 4 3KVA Rear Panel view

## 2.2 The principle of the product

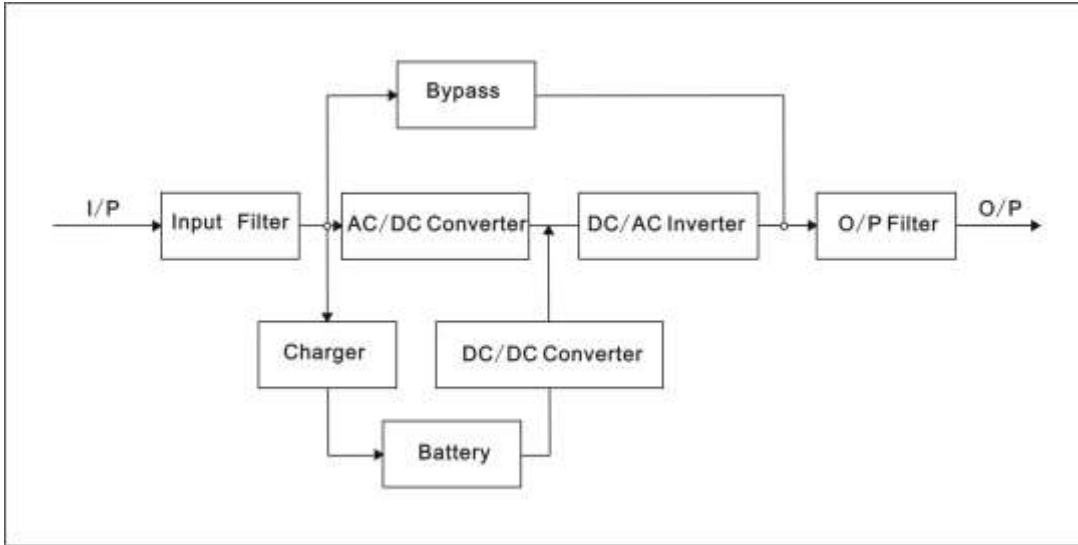

Fig 5 UPS Principle Diagram

1. Input filter: Complete filtering the input AC utility power to provide the clean power for UPS.
2. AC/DC converter: Convert the filtered AC mains to DC and boost the DC for DC/AC inverter.
3. DC/DC booster: When the UPS works in battery mode, the circuit boosts the DC for DC/AC inverter.
4. DC/AC inverter: Convert the boosted DC to stable AC output.
5. Bypass: When overload or failure of inverting happen in the UPS, it transfers to bypass mode to supply power to loads.
6. Charger: Standard unit provides 1A; long backup unit provides 7A.
7. Battery: Sealed Lead Acid Battery.
8. Output filter: Complete filtering the output of the UPS to provide the clean power for loads.

## 2.3 Model

UPS sort	MODEL NO	Remark
Standard unit	1KVA	Internal 1A charger, 2 PCS 7AH batteries
	2KVA	Internal 1A charger, 4 PCS 7AH batteries
	3KVA	Internal 1A charger, 6 PCS 7AH batteries
Long backup unit	1KVA	★internal 6A charger, external 24V battery
	2KVA	★internal 6A charger, external 48V battery
	3KVA	★internal 6A charger, external 72V battery

The 12V/9AH battery which is sealed lead acid maintenance free can be chosen as internal battery of the standard unit.

The 7A charger can be chosen as internal charger of the long backup unit.

Two internal chargers can be used in long backup unit.

### 3. INSTALLATION

#### 3.1 Unpacking and inspection

1. Unpacking the box and check the UPS. If damaged or some parts missing, don't start the machine and inform your supplier.
2. Check the box content (please consult Box Content Table).
3. Check if the UPS is that you wanted to purchase. You can verify it on the label on the rear panel of the UPS.

#### 3.2 Notes

1. Please place the UPS in a clean, stable environment, avoid the vibration, dust, too humidity, flammable gas and liquid, corrosive.
2. The ambient temperature around UPS should keep in a range of 0°C~40°C. If UPS works above 40°C, it is required that the rated value of the largest load decreases 12% while the temperature increases every 5°C . The highest temperature cannot be more than 50°C when UPS works.
3. UPS should be placed in a sufficiently ventilated place.

#### 3.3 UPS input connection

Connect the UPS to the mains by input power cable which is equipped with the UPS.

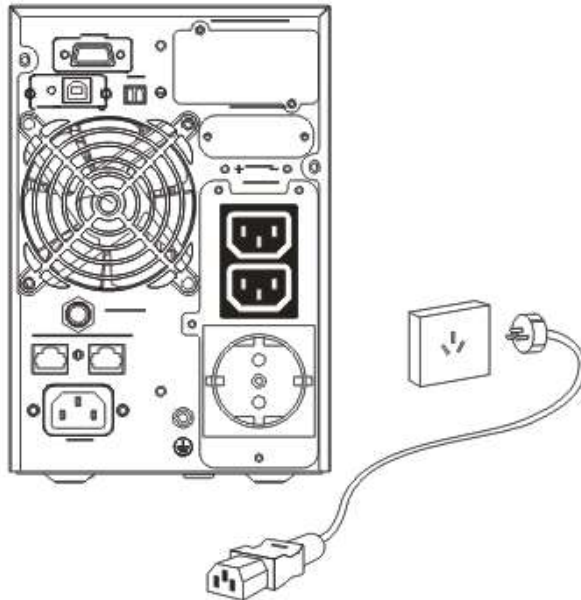

Fig 6 Input Connection

#### 3.4 UPS output connection

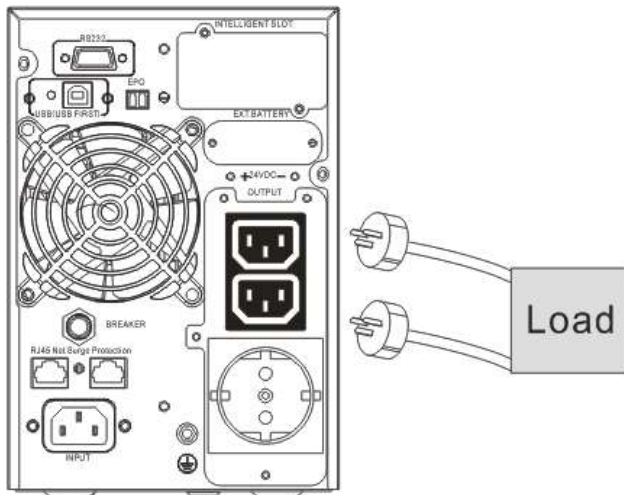

Fig 7 Output connection

### 3.5 Long backup external battery connection

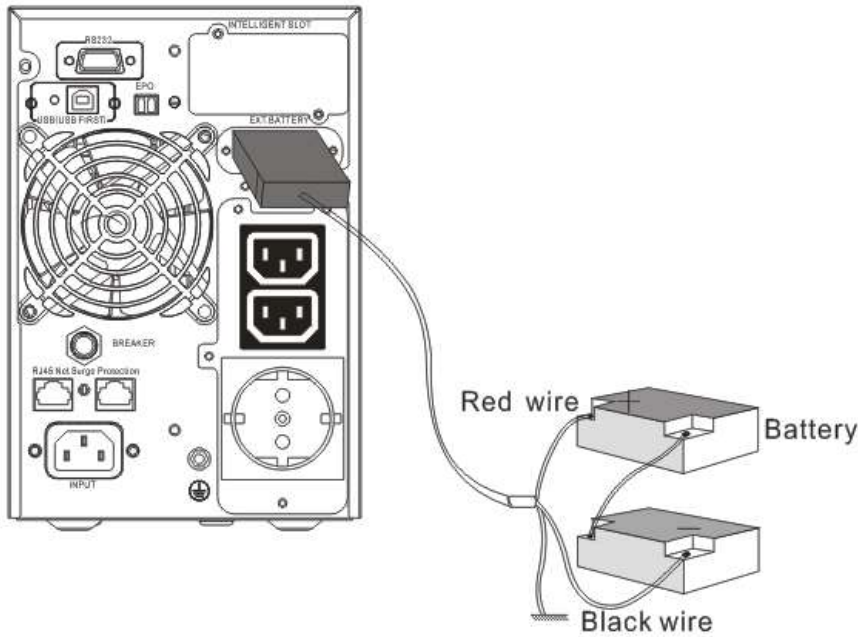

Fig 8 Battery connection



**Warning:**

- ★ Before installing battery, make sure that UPS and breaker are all turned off. Remove all your metallic adornment such as finger ring, watch, and so on before connecting battery.
- ★ No anti-connection or short circuit between the battery anode and cathode forever. Red cable connect with battery anode “+” and black cable connect with cathode “-”.
- ★ Please use the screwdriver with insulating handle. Do not lay the tools or metallic goods on the battery.



**Notice:**

- ★ When using the external battery, It is best to use external battery cable which matches with the equipment.
- ★ When connecting load to UPS, first turn off load and then connect the power cable and finally turn on load one-by-one.
- ★ Inductance loads such as motor, fluorescent lamp, photocopier are strictly prohibited connecting to UPS to avoid damage.
- ★ Plug UPS on the special socket with over-current protection, the power socket that used should be connected with ground wire.
- ★ UPS is likely to have output voltage no matter whether the power input cable is plugged in mains input socket. If you wish UPS have no output, first break off the switch and then cancel the mains.
- ★ When connect laser printer, select the capacity of UPS according to the UPS start power because the startup power is higher.

## 4. PANEL DISPLAY, OPERATION AND RUNNING

The operation is simple, operators only need to read the manual and follow the operation instructions listed in this manual without any special training.

### 4.1 Faceplate display illumination

#### 4.1.1 Keys function

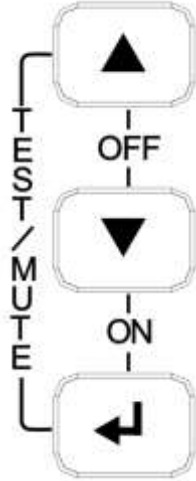

Fig. 9 Front panel buttons instruction

#### ON key +

Press and hold this key for more than half a second to turn on the UPS.

#### OFF key +

Press and hold this key for more than half a second to turn off the UPS.

#### TEST/MUTE key +

Press and hold the key for more than 1 second in Line mode or economical mode: UPS runs the self-test function.

Press and hold the key for more than 1 second in battery mode: UPS runs the mute function.

#### INQUIRING key or

*Non-function setting mode:*

Press and hold the key for more than half a second (less than 2 seconds): Indicate the items of the LCD item section orderly.

Press and hold this key for more than 2 seconds: Circularly and orderly display the items every 2 seconds, when press and hold the key for some time again, it will turn to output status.

*Function setting mode:*

Press and hold the key for more than half a second (less than 2 seconds): Select the set option.

#### FUNCTION SETTING key

*Non-function setting mode:*

Press and hold the key for more than 2 seconds: Function setting interface.

*Function setting mode:*

Press and hold the key for more than half a second (less than 2 seconds): Affirm the set option.

Press and hold the key for more than 2 seconds, exit from this function setting interface.



### 4.1.2 The function of LED indicators

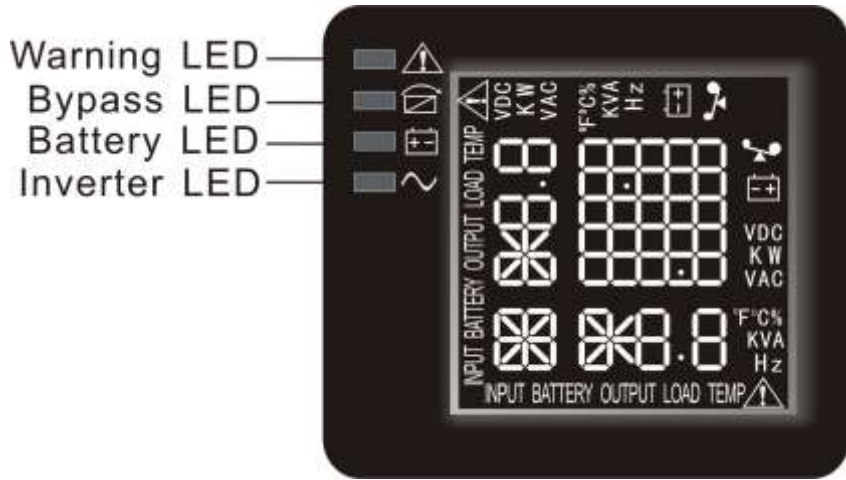

- Warning red LED is on: UPS is fault. For example: Overload beyond the allowed time, inverter fault, BUS fault, over temperature fault etc.
- Bypass yellow LED is on: UPS is alarming. For example: Bypass mode supply power and etc.
- Battery yellow LED is on: UPS is alarming. For example: Battery mode supply power and etc.
- Inverter green LED is on: UPS is normally powered by mains or ECO mode or battery mode.

After starting the UPS, the four LEDs will light and go out one-by-one. It circulates several times until starting the UPS successful.

**NOTE:** As to the LED indication in different modes, please refer to the LED display panel and warning table.

### 4.1.3 LCD display functions

The LCD displays as following picture

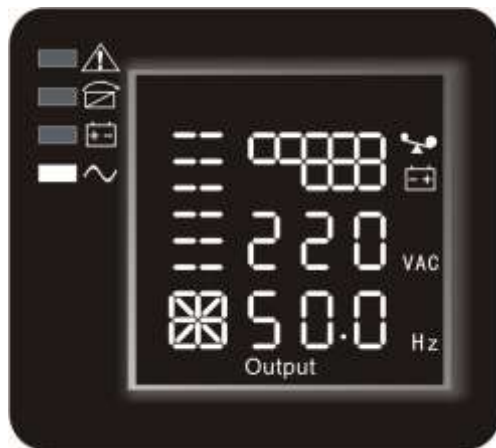

LCD display comprises numerical value section, capacity graphics section, fan-status graphics section and charger-status graphics section.

- Numerical value section: display the corresponding numerical value of inquiring items(output, load, temperature, input, battery), for example, as the graphics shows above, the output voltage is 220v, the output frequency is 50Hz.
- Capacity graphics section: display the capacity of the battery and load. Every pane represents 20% capacity. As graphics showed above, the capacity of the battery is 80% -100%( 5 panes), the load reaches 40%-60%(3 panes). When UPS is overload, the icon will flash, when capacity of battery is too low or disconnected, the icon will also flash.

Fan-status graphics section: display if the fan works normally. When the fan works normally, it will show the dynamic fan blades rotating; when the fan works abnormally, the icon  will keep on flashing with the warning.

Charger-status graphics section: display the status of the charger. When charger works normally, the corresponding icon will vary dynamically and orderly, just as graphics (1)



when charger works abnormally, the icon will flash in a whole, as graphics (2):

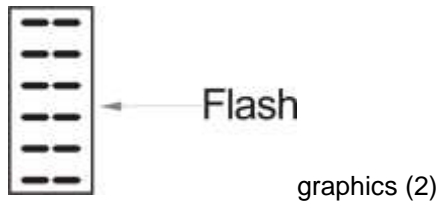

When UPS is in battery mode, the number of the icons of the charger-state section will vary according to the changeable capacity of the battery (pane). For example, there are five panes in picture below, (as the right picture of the graphics (3)), so the corresponding number of icons is five rows (as the left picture of the graphics (3)), followed by this rule



## 4.2 Operation

### 4.2.1 Turn on operation

#### Turn on the UPS in line mode

- 1 Once mains power is plugged in, the UPS will charge the battery, at the moment, LCD shows that the output voltage is 0, which means UPS has no output. If it is expected to have output of bypass, you can set the bps "ON" by LCD setting menu.
- 2 Press and hold the ON key for more than half a second to start the UPS, then it will start the inverter.
- 3 Once started, the UPS will perform a self-test function, LED will light and go out circularly and orderly. When self-test finishes, it will come to line mode, the corresponding LED lights, UPS is working in line mode.

#### Turn on the UPS by DC without mains power

- 1 When mains power is disconnected, press and hold the ON key for more than half a second to start UPS.
- 2 The operation of UPS in the process of start is almost the same as that when mains power is in. After finishing the self-test, the corresponding LED lights and UPS is working in battery mode.

### 4.2.2 Turn off operation

#### Turn off the UPS in line mode

- 1 Press and hold the OFF key for more than half a second to turn off the UPS and inverter.
- 2 After UPS shutting down, LED go out and there is no output. If output is needed, you can set bps "ON" on LCD setting menu.

#### Turn off the UPS by DC without mains power

- 1 Press and hold the OFF key for more than half a second to turn off the UPS.

- When turning off the UPS, it will do self-testing firstly. LED light and go out circularly and orderly until there is no display on the panel.

#### 4.2.3 UPS self-test/mute test operation.

- When UPS is in line mode, press and hold the self-test/mute key for more than 1 second, LEDs light and go out circularly and orderly. UPS comes to self-test mode and tests its status. It will exit automatically after finishing testing, LED resume.
- When UPS is in battery mode, press and hold the self-test/mute key for more than 1 second, the buzzer stops beeping. If you press and hold the self-test/mute key for one more second, it will restart to beep again.

### 4.3 Parameter setting



UPS has setting function. It can run the setting on any mode. After setting, it will become effective at once when meets some standards. The set information can be saved only when the battery connected and normally turning off the UPS.

The operation of setting is as following:

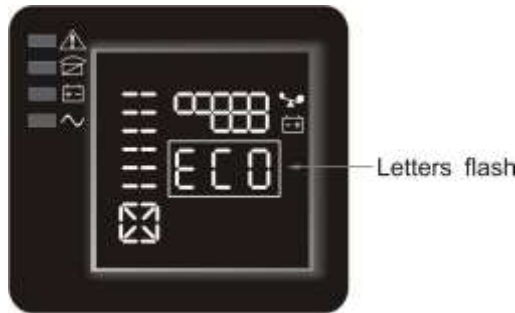

#### 4.3.1 ECO mode setting

- Enter the setting interface. Press and hold the function setting key  for more than 2 seconds, then come to setting interface, the letters "ECO" will flash as following:



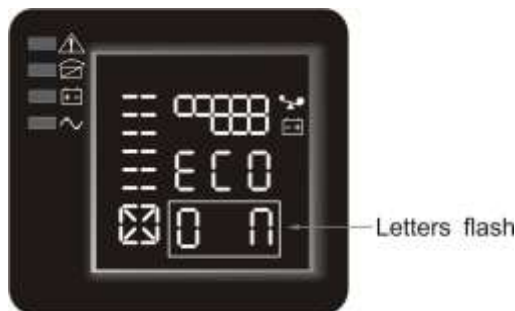

- Enter the ECO setting interface. Press and hold the function setting key  for more than half a second (less than 2 seconds), then come to setting interface of ECO, at this time, the letters "ECO" will light for a long time. The "ON"(or OFF) below the ECO will flash. Press and hold the inquiring key  for more than half a second (less than 2 seconds) to determine whether the ECO function is used or not. If used, the corresponding word is "ON", if not, the word is "OFF". It can be determined by yourself.









- Confirm the ECO selecting interface. After selecting ON or OFF, press and hold the function setting key  for more than half a second (less than 2 seconds). Now, the ECO setting function is completed and the "ON" or "OFF" below the "ECO" will light without flash.
- Exit from the setting interface. Press and hold function setting key  for more than 2 seconds, exit from the setting interface and turn to main interface.



### 4.3.2 Output on bypass mode setting (bPS)

1 Enter the setting interface. Press and hold the function setting key  for more than 2 seconds, then come to setting interface, Press and hold the function setting key  for more than half a second (less than 2 seconds), select the function setting, choose the auto battery test setting interface, at the moment, the letters "ABT" will flash as following:





2. Enter the Output on bypass interface: Press and hold the configuration key  for more than half a second (less than 2 second), and enter in bPS configuration interface, now "bPS" letters will remain fix. and "ON" (or OFF) letters below bPS will be flashing. Press key  to select ON or OFF. If bPS function must be used, then select "ON", otherwise select "OFF" if you don't intend to use this function.
- 3 Confirm the bPS setting interface: After having selected either ON or OFF, press configuration key  for more than half a second (less than 2 second) to confirm the choice. Now config of bPS function is completed and "ON" or "OFF" letters below "bPS" will remain fixed.
- 4 Select the Voltage Range of the bPS function: after selecting ON press the key for more than half second (less than 2 seconds)  and select the higher value 5%, + 10%, + 15%, + 25% ( default is + 25%) using the key , confirm by pressing for more than half second (less than 2 seconds) the key , go to the lower value selection, proceed in the same way.
- 5 Exiting the Configuration Interface: Press and hold the Configuration Function key  for more than 2 seconds to exit this configuration interface and return to the Main Interface..
- 6 After configuring the bPS "ON", when the UPS is connected to the mains without turning it on, the output voltage is fed through the bypass.

### 4.3.3 Output Voltage selection function setting (OPU)

1 To enter the configuration interface, press and hold the Configuration function key  for more than 2 seconds, then access the Configuration Interface. Press the key  until you reach the OPU menu (3), the word "OPU" flashes:



- 2 Start the Output Voltage selection mode interface: Press and hold the configuration function key  for more than half second (less than 2 seconds), the OPU configuration output interface is accessed, at this point the write "OPU" will remain fixed. The numeric value under OPU will blink. Press the key  to select the numeric value of the desired "OPU" function (output voltage). Selectable voltages are 208V, 220V, 230V, 240V, (the default is 220V).
3. Confirm the Output Voltage selection mode interface. After selecting the numeric value, hold down the function configuration key  for more than half a second (less than 2 seconds). Now, the "OPU" mode configuration is completed and the numeric value under "OPU" will remain fixed.



- Exit the configuration interface. Press and hold the button for more than 2 seconds to exit this configuration interface to return to the main interface.











**Note:**

When configuring the output voltage, the load should be off or disconnected from the UPS.



#### 4.3.4 Number and type of battery selection function (bAt)

- To enter the configuration interface, press and hold the Configuration function key  for more than 2 seconds, then access the configuration interface. Press the key  until you reach the bAt menu (4), the word "bAt" will flash:



- Start the number and battery type selection interface: Press and hold the configuration function key  for more than half a second (less than 2 seconds), enter the bAt configuration interface, then "bAt" will remain fixed and the word "ON" (or OFF) under bAt will blink. Press the key  to select ON or OFF.
- Confirm the bAt selection interface: After selecting ON or OFF, pressing the configuration function key  for more than half second (less than 2 seconds) confirms the selection. If OFF is selected, the procedure ends and returns to the initial configuration. If ON is selected, the numeric value of the additional battery cabinets is configured, select the value using the key , confirm by pressing for more than half a second (less than 2 seconds) key , scroll to the battery type selection, select the value using the key , confirm by pressing for more than half second (less than 2 seconds) the key .
- Exit the configuration interface: Press and hold the configuration function key  for more than 2 seconds to exit this configuration interface and return to the Main Interface.



#### 4.3.5 function setting (Seg)

- To enter the configuration interface, press and hold the configuration function key  for more than 2 seconds, then access the configuration interface. Press the key  until you reach the Seg (5) menu, the word "Seg" will blink:







The function is present in the menu but not available for the following models:  
MISSION1000 - MISSION2000 - MISSION3000.



4.3.6 Battery discharge time setting function (tod)

1. To enter the configuration interface, press and hold the configuration function key  for more than 2 seconds, then access the Configuration Interface. Press the key  until you reach the "tod" menu (6), the word "tod" flashes:



- 2 Start the selection interface Battery discharge time setting: Press and hold the configuration function key  for more than half a second (less than 2 seconds), enter the "tod" configuration interface, at this point the write "Tod" will remain fixed. The numeric value under the word "tod" will blink. Press the key  to select the desired option between 1m - 2m - 3m (default option) - 5m - 10m - 30m - 1h - 2h - 3h - 4h - OFF (no time limitation).
- 3 Confirm the "tod" selection: After selecting the desired time, pressing the configuration function key  for more than half second (less than 2 seconds) confirms the selection. Now, the configuration of the "tod" function is completed and the selection under "tod" will remain fixed.
- 4 Exit the Configuration Interface. Press and hold the configuration function key  for more than 2 seconds to exit and return to the main interface.
- 5 When the "tod" function is activated, the Ups (in battery operation) will turn off at the end of the selected time by powering off the connected devices.

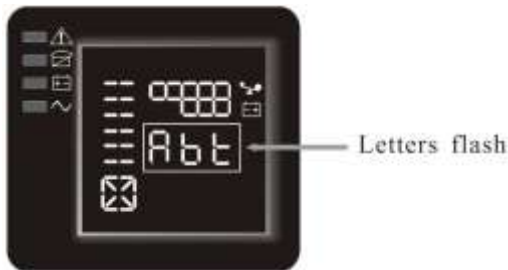

4.3.7 Auto battery test function setting (Abt)

- 1 Enter the setting interface. Press and hold the function setting key  for more than 2 seconds, then come to setting interface, Press and hold the function setting key  and select the menu bPS (2), the letters "bPS" will flash as following:
- 2 Enter the auto battery test setting interface. Press and hold the function setting key  for more than half



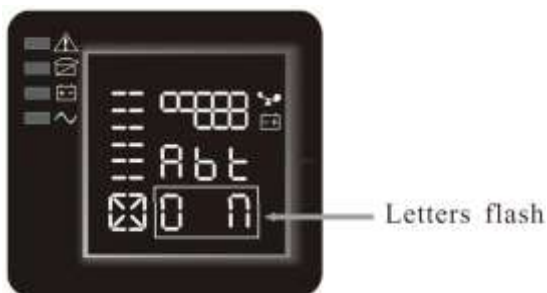

a second (less than 2 seconds), then come to setting interface of ABT, at this time, the letters "ABT" will light for a long time. The "ON" below the ABT will flash. Press and hold the inquiring key  for more than half a second (less than 2 seconds) to determine whether the ABT function is used or not. If used, the corresponding word is "ON", if not, the word is "OFF". It can be determined by yourself.







- 3 Confirm the auto battery test setting interface. After selecting ON or OFF, press and hold the function setting key  for more than half a second (less than 2 seconds), Now, the ABT setting function is completed and the "ON" or "OFF" below the "ABT" will light without flash.
- 4 Exit from the setting interface. Press and hold function setting key  for more than 2 seconds, exit from the setting interface and return to main interface.
- 5 When the ABT function is set to ON , the UPS will automatically do battery test every 30 days for 10 seconds if utility is available

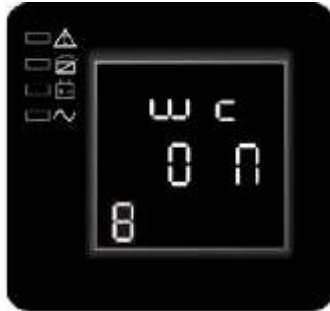

#### 4.3.8 Warning Code function setting (wc)

- 1 To enter the configuration interface, press and hold the configuration function key  for more than 2 seconds, then access the configuration interface. Press the key  until you reach the "wc" (8) menu, the word "wc" flashes:





- 2 Start the Warning Code selection interface: Press and hold the configuration function key  for more than half second (less than 2 seconds), enter the configuration wc interface, at this point the wc will remain fixed and the word "ON" (or OFF) under wc will flash. Press the key  to select ON or OFF.
- 3 Confirm the wc selection interface: after selecting ON or OFF, pressing and holding the configuration function key  for more than half a second (less than 2 seconds) confirms the selection. Now, the configuration of the wc function is completed and the word "ON" or "OFF" under "wc" will remain fixed.
- 4 Exit the configuration interface. Press and hold the configuration function key  for more than 2 seconds to exit this configuration interface and return to the main interface.
- 5 When the wc function is set to ON, the Ups will show cyclically (2 ~ 5 sec) any alarm messages. For alarm messages refer to the table in Appendix1.

#### 4.3.9 Emergency Power Off polarity function setting (EPO)

- 1 To enter the Configuration Interface, press and hold the Configuration Function key  for more than 2 seconds, then access the Configuration Interface. Press the key  until you reach the EPO menu (9), the word "EPO" flashes:





- 2 Start the EPO selection interface: press and hold the configuration function key  for more than half second (less than 2 seconds), enter the EPO Configuration Interface, then "EPO" will remain fixed and the word "- P" under EPO will blink. Press the key  to select "- P" or "+ P".
- 3 Confirm EPO Selection Interface: After selecting "- P" (short circuit executes EPO function) or "+ P" (open circuit performs EPO function), holding the configuration function key  more than half





second (less than 2 seconds) the selection is confirmed. Now, the EPO function configuration is completed and "" - P "or" + P "under" EPO "will remain fixed.

- 4 Exit the configuration interface. Press and hold the configuration function key  for more than 2 seconds to exit this configuration interface and return to the main interface.



#### 4.3.10 Discharge Low voltage function setting (Eod)

- 1 To enter the configuration interface, press and hold the configuration function key  for more than 2 seconds, then access the Configuration Interface. Press the key  until you reach the Eod menu (10), the word "Eod" flashes:





- 2 Start the Low Voltage selection mode interface: press and hold the configuration function key  for more than half second (less than 2 seconds), the EOD output interface is accessed, at this point the written "Eod" will remain fixed. The numeric value below Eod will blink. Press the key  to select the numeric value of the desired "Eod" function. Selectable voltages are 10.0V, 10.5V, 11V, (default is 10.0V).
- 3 Confirm the Low Voltage selection mode interface. After selecting the numeric value, hold down the function configuration key  for more than half a second (less than 2 seconds). Now, the "Eod" mode configuration is completed and the numeric value under "Eod" will remain fixed.
- 4 Exit the configuration interface. Press and hold the button  for more than 2 seconds to exit this configuration interface to return to the main interface.

#### 4.3.11 Frequency converter function setting (OPF)

- 1 To enter the configuration interface, press and hold the configuration function key  for more than 2 seconds, then access the Configuration Interface. Press the key  until you reach the OPF menu (11), the word "OPF" flashes:





- 2 Start frequency converter selection mode interface: press and hold the configuration function key  for more than half second (less than 2 seconds), access to the OPF converter configuration interface, at this point the write "OPF" will remain fixed. The value of the output frequency under OPF will blink. Press the key  to select from the available options. The selectable frequencies are 50Hz (output frequency fixed at 50Hz and converter mode activated), 60Hz (output frequency fixed at 60Hz and converter mode activated) and IPF (inverter mode inactive).
- 3 Confirm the frequency converter selection mode interface. After selecting the desired setting, hold down the function configuration key  for more than half a second (less than 2 seconds). Now, the "OPF" mode configuration is completed and the numeric value under "OPF" will remain fixed.



- 4 Exit the configuration interface. Press and hold the button  for more than 2 seconds to exit this configuration interface to return to the main interface.

**IPF:** The output frequency at the Ups is the same as that of the Ups input voltage. (inactive converter)  
**50.0Hz:** the output frequency at the Ups is set at 50Hz, regardless of the input frequency at the Ups input.  
**60.0Hz:** the output frequency at the Ups is fixed at 60Hz, regardless of the input frequency at the Ups input.

### 4.4 Parameters inquiring

Press and hold the inquiring key  or  for more than half a second (less than 2 seconds) to inquire about items. The inquired items include input, battery, output, load, temperature. The displayed items on LCD screen are showed as following:

**Output** Display the output voltage and output frequency of the UPS. As the following graphic shows, the output voltage is 220v, the output frequency is 50Hz.

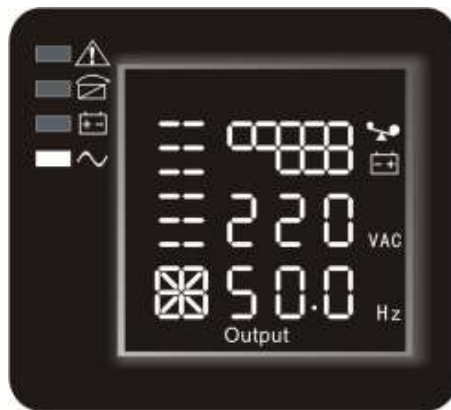

**Load:** Display the numerical value of the active power (W) and apparent power (VA) of the load. For example, as the following graphics shows: the WATT of the load is 100W, VA is 100VA (when disconnect load, it is a normal phenomenon to show a small numerical value of WATT and VA).



**Temperature:** Display the temperature of the inverter in the UPS. As the following graphics shows: the temperature of the inverter is 37°C.

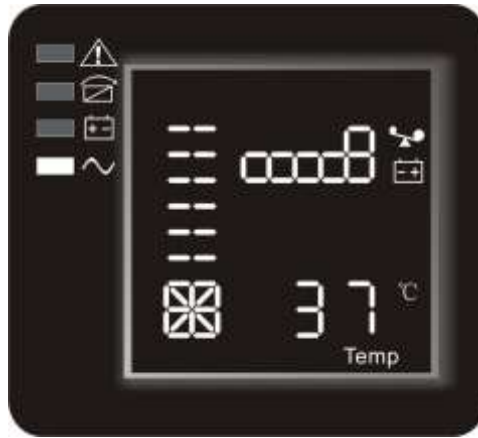

Input: Display the voltage and frequency of the input. As the following graphics shows: the input voltage is 210V, input frequency is 49.8Hz.



Battery: Display the voltage and capacity of the battery (determined by type). As the following graphics shows: the battery voltage is 28V, the capacity of battery is 100% (the capacity of battery is approximately reckoned according to the battery voltage).



Press and hold the inquiring key  for more than 2 seconds, LCD begins to display the items circularly and orderly which transfer to another every 2 seconds. Press and hold the key for some time again, it will return to output status.

## 4.5 Run mode

### 4.5.1 Bypass mode

LED indications on front panel in bypass mode are as following:

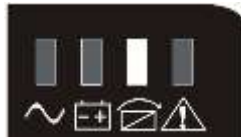

Bypass yellow LED is on, the buzzer beeps once every 2 minutes. The warning red LED is on when beeping, LCD displays are according to the exact load and battery capacity.

Turn to bypass mode under the following two conditions:

1. Turn off the UPS in line mode while start the bypass output.
2. Overload in line mode.

**NOTE:** When UPS is working in bypass mode, it has no back up function.

#### 4.5.2 Line mode

LED indications on front panel in line mode are as following: The inverter green LED is on.



When input AC mains is in line with the working conditions, UPS will work in line mode.

#### 4.5.3 Battery mode

LED indications on front panel in battery mode are as following: both the inverter green LED and battery yellow LED are on, the buzzer beeps once every 4 seconds. The warning red LED is on when beeping.



When the mains power down or instable, UPS will turn to battery mode at once.

#### 4.5.4 ECO mode

LED indications on front panel on ECO mode are as following: both the inverter green LED and bypass yellow LED are on.



When the input mains meets the input range of the ECO mode and start the ECO function, the UPS will works on ECO mode. If input AC mains exceeds the range of ECO several times in a row in a minute but stays in inverter input range, UPS will work on AC inverting mode automatically.

#### 4.5.5 Fault mode

LED indications on front panel in fault mode are as following: warning red LED is on



Fault mode (LCD interface on which the fault code display)

When UPS has fault. The warning LED is on and the buzzer beeps. UPS will turn to fault mode. UPS cuts off the output and LCD display fault codes. At the moment, you can press the mute key to make the buzzer stop beeping temporarily to wait for maintenance. You can also press the OFF key to shut down the UPS when confirm that there is no serious fault.

NOTE: As for corresponding information of the fault code, please refer to chapter 6.1



NOTICE:

- ★ The following process must be performed if UPS is connected with generator:
- ★ First turn on generator, after it runs stably connect output power of generator to UPS input terminal, then turn on UPS. After UPS turned on, please connect load one-by-one.
- ★ It is recommended that the generator capacity is as twice as UPS rated capacity
- ★ You'd better not use the ECO mode when the quality of the input AC mains is not good.

## 5 MAINTENANCE

Only minimum maintenance is required for this series of UPS. The battery is sealed lead acid maintenance free. It only needs to be kept charging to obtain the expected life. Whether it is started or not, the UPS would charge batteries once it is connected to mains and provide protection for over-charging and deep discharging.

### 5.1 Battery maintenance

1. It is recommended that the batteries are manually charged or discharged once every three or four months if UPS has not been used for a long time or the power is long-term uninterruptible. The battery will be fully discharge to low-voltage protection shutdown. Then it needs to be fully charged once.
2. In high temperature area, batteries should be manually charged and discharged once every two months. The process is the same as that said above.
3. Under normal circumstances of using, the battery working life is three to five years. If you find that the battery do not act well such as obviously shortening of backup time, too much imbalance on battery voltage so on, the battery should be replaced as soon as possible, which must be performed by qualified personnel.
4. When replace battery, it is recommended to change battery all together instead of changing separately.



NOTICE:

- ★ Before replacing batteries, first please turn off the UPS and break off the mains. Remove your metallic adornment such as finger ring, watch and so on.
- ★ When replace batteries, please use the screwdriver with insulating handle. Do not lay the tools or metallic goods on the battery.
- ★ Never reverse or short circuit between the battery anode and cathode.

## 6 TROUBLESHOOTING AND PERFORMANCE OF PRODUCT

The following messages are the information that users would find on UPS when it meets some problems. Users can judge if the fault is caused by external factors and know how to deal with it by making full use of the information.

1. Fault indicator on, indicates that the UPS has detected some faults.
2. Buzzer beeps, indicates that UPS need to be paid attention to, if beeps for a long time, it means that there is something wrong with the machine.
3. If you need help, contact our service department, the following messages should be provided for analysis:
  - ◆ UPS MODEL NO. and SERIAL NO.
  - ◆ Date of fault happened
  - ◆ Detailed description of the problem (include indicator statements on panel)

## 6.1 LED indication and warning table

### Appendix 1: Fault codes

FAULT CODE	FAULT CAUSATION
00–19	Bus Fault
20–39	Inverter Fault
40–44	Over Heat
45–49	Output short circuit
50–54	Overload
55–59	Output Relay Fault
60–64	Input NTC Fault
65–69	Auxiliary Power Fault
70–74	Input Fuse Fault
99	Others

### Appendix 2: The corresponding working status of indications

NO	WORKING STATUS	INDICATION				WARNING	REMARKS
		NOR	BAT	BPS	FAULT		
1	Line mode						
	Normal voltage	•				None	
	High/low voltage protection, turn to battery mode	•	•		★	Once every four seconds	
2	Battery mode						
	Normal voltage	•	•		★	Once every four seconds	
	Battery Voltage abnormal warning	•	★		★	Once per second	
3	Bypass mode						
	Main AC Normal voltage in bypass mode			•	★	Once every two minutes	Eliminate after starting the UPS
	Main AC high voltage warning in bypass mode				★	Once every four seconds	
	Main AC low voltage warning in bypass mode				★	Once every four seconds	
4	Battery disconnect warning						
	Bypass mode			•	★	Once every four seconds	Affirm if the battery switch is closed
	Inverting mode	•			★	Once every four seconds	Affirm if the battery switch is closed
	Power up or start					Six times	Affirm if the battery is connected well
5	Output overload protection						
	Overload warning in line mode,	•			★	Twice per seconds	Remove the less important loads
	Overload in line mode, protection			•	•	Long beeps	Remove the less important loads
	Overload warning in battery mode	•	•		★	Twice per second	Remove the less important loads
	Overload in battery mode, protection	•	•		•	Long beeps	Remove the less important loads
6	Overload warning in bypass			•	★	Once every 2	Remove the less important

	mode					seconds	loads
7	Fan fault (fan icon flash)	▲	▲	▲	★	Once every 2 seconds	Check if the fan is blocked by object.
8	Fault mode				●	Long beeps	If display fault code and icon  lights, contact for maintenance when you can't deal with it by yourself.

- indicator lights for a long time
- ★ indicator flashes
- ▲ the status of indicator depends on other conditions

**NOTE:** When UPS has fault, it is convenient for you to know the working status of UPS and the exact information about the fault promptly by referring to the two tables listed above.

## 6.2 TROUBLESHOOTING

When the fault occurs, firstly, perform troubleshooting by referring to the troubleshooting table. If the fault still exists, please contact the franchiser.

FAULT	CAUSE	SOLUTION
The "INPUT" letters on LCD display section flashes	Anti-connection of mains live and neutral or mains is out of range	Re-connect the input power cable and make a correct connection
Battery capacity indicator flashes	Battery low voltage or battery disconnected	Check UPS battery, connect battery well, if battery damaged, replace it
Mains normal, but UPS has no input	UPS input breaker open circuit	Press the breaker for reset
Short back up time	Battery not fully charged	Keep UPS connecting with mains power for more than 8 hours, recharge battery
	UPS overload	Check the usage of loads, remove some redundant devices
	Battery aged	When replace battery, contact franchiser to get battery and relative assembly
UPS doesn't startup after pressing the ON key	Didn't press the combination keys of "on"	Press the two keys at the same time
	UPS has no battery connected or battery voltage low and too many loads connected	Connect UPS battery well, if battery voltage low, please turn off UPS and remove some loads, then start UPS
	Fault occurs inside UPS	Contact supplier for servicing
The icon of charger status on LCD display flashes and buzzer beeps once per second	Charger doesn't work normally or battery aged	Contact supplier for servicing

### 6.3 EMC STANDARD / SAFETY STANDARD

Our product are manufactured according to the following EMC international grade standard and has passed the CE authentication:

EMC STANDARD NUMBER	SAFETY STANDARD NUMBER
IEC62040-2	IEC62040—1
IEC61000-4-2	GB4943-5
IEC61000-4-3	
IEC61000-4-4	
IEC61000-4-5	

### 6.4 PRODUCT PERFORMANCE

MODEL		MISSION 1000	MISSION 2000	MISSION 3000	
RATED CAPACITY (VA/W)		1000VA / 800W	2000VA / 1600W	3000VA / 2400W	
INPUT	Input	Single phase and earthing			
	Voltage range	115±5VAC - 295±5VAC			
	Frequency range	45Hz-55Hz@50HZ/55Hz-65Hz@60HZ			
	Power factor	≥0.98			
	ECO range	Setting output voltage ±20VAC			
	Bypass range	186VAC - 252VAC			
	Current harmonic	≤7% (100% non linear load)			
OUTPUT	Output style	Single phase and earthing			
	Rated voltage	208/220/230/240VAC			
	Power factor	0.8			
	Voltage precision	±2%			
	Output Frequency	Line mode	1. When input frequency is in the range, the output frequency is the same as that of input. 2. When input frequency is out of the range, the output frequency is (50/60±0.2)Hz when turn to battery mode.		
		Battery	(50/60 ±0.2)Hz		
	Crest ratio	3:1			
	Transfer time	Mains ↔ battery = 0ms			
	Overload capacity	Battery mode	108%±5%<load≤150%±5% >30s cut off output and warn, 150%±5%<load<200%±5% >300ms cut off output and warn		
		Line mode	108%±5%<load≤150%±5% >30s transfer to bypass and warn 150%±5%<load<200%±5% >300ms transfer to bypass and warn		
	Efficiency	Line mode	Full load≥88%		
		Battery mode	Full load≥85%		
		ECO	Full load≥94%		
Output voltage distortion		≤3%(100% linear load)			
		≤5%(100% non linear load)			

<b>BATTERY</b>	Input battery voltage	24VDC	48VDC	72VDC
	Internal battery capacity	2	4	6
	Internal battery type	12V/7AH sealed lead acid maintenance free battery (only refers to standard UPS)		
	Backup time	Full load ≥4min (only refers to standard UPS), As for long backup UPS, the backup time is determined by the capacity of battery.		
	Charge current (A)	1		

◆ Work Environment

MODEL	MISSION 1000	MISSION 2000	MISSION 3000
Temperature	0°C ~ 40°C		
Relative humidity	0~95% non condensing		
Altitude	<1500mt if >1500mt lower the rated power for use		
Store temperature	-25°C ~ 55°C		

◆ Mechanical Specification

MODEL	MISSION 1000	MISSION 2000	MISSION 3000
Dimension W*D*H (mm)	144 x 368 x 215	191 x 469 x 339	
Gross weight/Net weight (kg)	10,5 / 9,7	21,6 / 20,0	26,2 / 24,6

◆ Box content

MODEL	MISSION 1000	MISSION 2000	MISSION 3000
User Manual	●		
Software (CD-ROM)	●		
RS232 Cable	1		
USB Cable	1		
Input Cable (IEC)	1	1	NO
Output Cable (IEC)	2	3	3



## 6.5 COMMUNICATION INTERFACE

### 6.5.1 RS232 communication interface

This UPS provides a standard DB9 communication interface on its rear panel, the definition of the pins is as following:

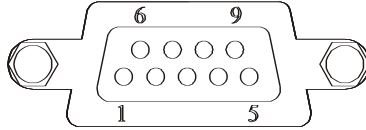

PIN	DEFINITION
1-4-6-7-8-9	Not used
2	TX
3	RX
5	GND

### 6.5.2 RS232 cable specifications

When connecting the UPS with PC by RS232 cable, it needs to use the standard RS232 cable, the detailed cable No. are as following:

PIN 1 (female) to computer serial port	PIN 2 (male) to UPS serial port
2	2
3	3
5	5

### 6.5.3 Optional communication interface

#### 1. USB communication interface

USB communication interface: Install the intelligent monitoring software UPSilon2000 which is equipped with the UPS. Then it can achieve the communication with monitoring device directly. When RS232 and USB are provided, only one of them will be chosen and USB is preferred.

#### 2. Intelligent slot

The following intelligent cards can be installed into the intelligent slot of the UPS: intelligent USB card, intelligent SNMP card and intelligent dry contact card. Support the hot plug and play. Any card of them can be used according to users' requirements.

- Intelligent USB card: Use the monitoring function of the USB interface system to monitor and manage the power source of the UPS.
- Intelligent SNMP card: When connecting to the internet by SNMP card, it communications with the monitoring computer to monitor power source of the UPS from far end.
- Intelligent dry contact card: Use the monitoring function of the dry contact interface system to monitor and manage the power source of the UPS.

**NOTE:** Remove the cover before installing the optional accessories.  
Intelligent Slot can be used together with RS232.  
The operating instruction of the UPSilon2000 can be acquired from the CD.  
As for the operating instructions of the intelligent USB card, SNMP card and dry contact card, please refer to the relative special instructions.

### 6.5.4 Emergency Power Off (EPO)

The EPO function is used to shutdown the Ups by remote. This function, for example, can be used to turn off the load connected to the UPS by means of a thermal relay in case of over temperature in a room. When the EPO is activated, the UPS immediately switches off the output by disconnecting power from all the loads connected, the Ups remain alarmed by displaying the "EPO ON" message on the display, the Red LED will turn on and start a continuous acoustic signaling.

You can also activate the EPO function via the buttons on the Ups front panel. To do this, simultaneously press all three buttons for about a second. The ups will be in the same condition described above.

In both conditions to disable the EPO function, you must press the same combination of three keys, the word "EPO OFF" will be displayed, the red LED will blink 2 times (at the same time with 2 beeps) every 4 seconds.

To come back to normal operation press buttons  for selecting OFF.

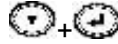
Now it is possible to restart the Ups by pressing buttons  ON.

EPO Connections			
Wire	Function	Terminal Wire Size Rating	Suggested Wire Size
EPO	L1	4 – 0.32 mm2 (12–22 AWG)	0.82 mm2 (18 AWG)
	L2		

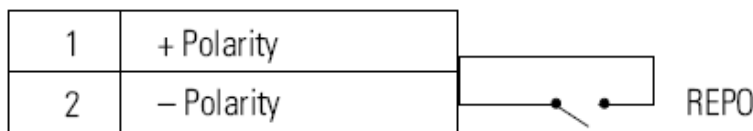

You can set the polarity of the EPO to refer to paragraph 4.3.8 (Emergency Power Off polarity configuration).

NOTE: Depending on the user's configuration you can keep the UPS short-circuited by opening the EPO contacts. To restart the Ups, re-open or re-connect contacts and power up the Ups manually.

The maximum short-circuit resistance is 10 ohm.

To avoid accidental loss of load, it is always advisable to test the EPO function before applying the load.

Leave the EPO connector installed in its seat on the back of the UPS even if the EPO function is not used.