

UPSmodem

DC UPS



Uninterruptible Power Systems

INDEX

1. Package Contents	2
2. Product Overview	2
3. Installation and Operation	2
4. Applications	3
5. Important Safety Warning	3
6. Trouble Shooting	3
7. Specifications	4
8. Approximate Back-up Time Table	4
Warranty	5

Thanks for purchasing our UPS, it is safe and reliable, so few maintenance is required.
Read this manual carefully and completely. It includes instructions of safety installation and operation. They will help your UPS obtain the longest life and service. This manual accounts the internal working principle and the relative protection functions. This manual also contains information about the usage of the equipment.
Please obey the instructions and all the warning stated in the manual or on the machine. Don't operate the machine before finishing reading the safety and operation instructions.

Made in P.R.C



Note: Because of the continuous improvements, our products may differ somewhat from the contents included in this manual. You can contact local office to get the information when necessary.

1. Package Contents

- DC UPS adapter unit
- Instruction manual
- DC output connector

2. Product Overview

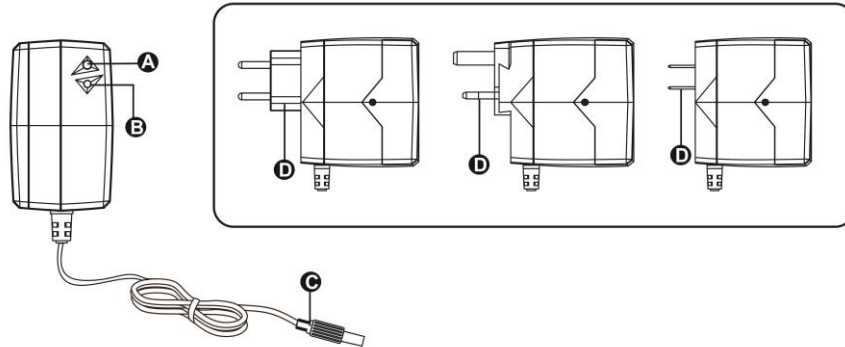

- A) On/Off Button
- B) LED indicator
- C) DC output connector
- D) AC input

3. Installation and Operation

NOTE: Before installation, please inspect the unit. Be sure that nothing inside the package is damaged.

Connect to Utility and Charging

Plug in the AC input plug (D) to the wall outlet. The UPS will be automatically turned on and green LED will light on. If battery is not fully charged, the UPS will auto charge battery and green LED will flash.

Connect the Loads

Plug in the loads to DC output connector (C) of the UPS. Then, connected device will be protected by UPS unit.

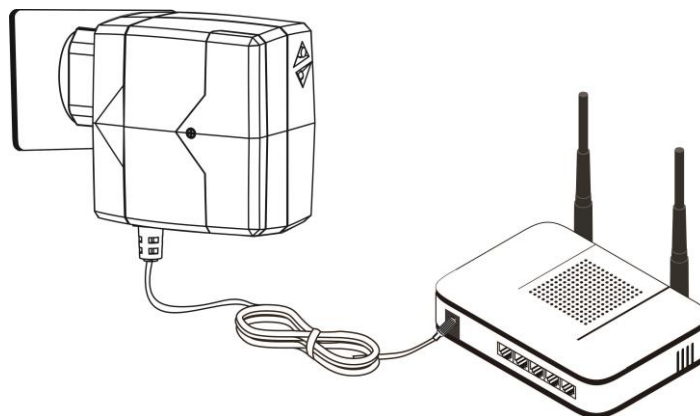

On/Off Button Operation

UPS will be automatically on when plugging into wall outlet under normal utility condition. If UPS is in fault mode, pressing button to restart the UPS. If the UPS is operated in battery mode, to avoid battery drain, please press and hold for 5 seconds to shut down the UPS. If the utility is not available and battery is fully charged, you may simply press this button to turn on the UPS.

LED Indication

This LED is two-color indicator: green or red color depending on operation status:

Status	Color	On/Flash
Power on with battery fully charged	Green	On
Power on with charging battery	Green	Steady Flash
UPS is on but power failure occurs. UPS will transfer to DC mode and battery is discharging	Green	Quick Flash
Any fault occurs on UPS	Red	On

4. Applications

The DC UPS is designed to provide emergency power backup to all kinds of DC-powered equipment such as routers, modems, set-top box, VOIP phone systems, surveillance system, alarm system, access control system and many critical telecom equipment.

5. Important Safety Warning

To safely operate this DC UPS, please read and follow all instructions carefully. Read this manual thoroughly before attempting to unpack, install, or operate. You may keep this quick guide for further reference.

- CAUTION! Do NOT place this unit under the hot and humid environment.
- CAUTION! Do NOT disassemble this product.
- CAUTION! If the battery level is low, please recharge battery immediately.
- CAUTION! When install or replace a new battery, be sure positive (+) and negative (-) are correctly connected. Otherwise, DC UPS will be damaged.
- CAUTION! Replace the Lithium-ion battery with the same type as stated in specifications.



6. Trouble Shooting

Use the table below to solve minor problems:

Problem	Possible Cause	Solutions
Red LED is on.	Overload or short circuit occurs on UPS and UPS transfers to fault mode.	Press button for more than 1 second and release to restart unit.
Battery backup time is shorter than nominal value.	Battery is far too low.	Contact your dealer to replace the special battery.
No output and LED indicator is not on.	Internal fault has occurred.	Contact your dealer.
Red LED is blinking	The battery insulating film has not been removed.	Remove the film by pulling it vigorously.

7. Specifications

MODEL	UPSmodem
AC INPUT	
Voltage Range	90 VAC ~ 264 VAC
Frequency	50 o 60 Hz
DC OUTPUT	
Voltage	12 Vdc \pm 5%
Max. Power	25W (2.1A)
BATTERY	
Type	Lithium-ion Battery
Nominal Voltage	3.7 Vdc
Capacity	2600 mAh
Typical Charging time	3 hours recover to 90% capacity
PHYSICAL	
Input Plug	Italian type
Output cable	1m Length DC Male Jack (OD 4mm, ID 1.7mm or OD 5.5mm, ID 2.5mm)
Dimension, DxWxH (mm)	68 x 42 x 74
Net Weight	280g

8. Approximate Back-up Time Table

MODEL	UPSmodem
Backup time	Min 30' - Max 3h (depends on the Modem type)

WARRANTY

Dear Customer,

Thank you for purchasing a NAICON product. We hope that you be satisfied.

If the product fails in warranty period, please contact your dealer or call +39 02 950031 or go to www.naicon.com/elsist. Before contacting your dealer or authorized service network, we recommend that you read the operating and maintenance manual carefully.

With this warranty, NAICON warrants the product to be free from defective in materials or workmanship for 2 years, as of the original delivery date.

If there are material or manufacturing defects during the warranty period, ELSIST affiliates, Authorized Service Centers or authorized resellers located in the UE region will repair or (at ELSIST discretion) replace the defective product or components under the terms and conditions below, without any charge for labor or spare parts costs. ELSIST reserves the right (in its sole discretion) to replace the components of defective products or low cost products with assembled parts or new or refurbished products.

Conditions.

1. This warranty will be valid only if the defective product is returned together with the sales invoice. ELSIST reserves the right to refuse warranty service in the absence of such documents or if the information contained therein is incomplete or illegible.
2. This warranty does not cover the costs and / or any damages and / or defects resulting from any modifications or adjustments made to the product, without prior written permission from ELSIST, in order to adapt the product to local technical or safety standards in countries other than those for which the product was originally designed and manufactured.
3. This warranty will be void if the model or serial number indicated on the product has been modified, deleted, removed or otherwise illegible.
4. Are excluded from the warranty:
 - Periodic maintenance and repair or replacement of parts subject to normal wear and tear.
 - Any modification or modification to the product, without prior written permission from ELSIST to enhance performance than those described in the User and Maintenance Manual
 - All costs of technical staff support and any transport from the customer's address to Assistance Center and vice versa as well as all the risks involved.
 - Damages due to:
 - a) Improper use, including but not limited to: (a) the use of the product for any purpose other than the intended use or failure to observe the ELSIST instructions for correct use and maintenance of the product, (b) installation or use of the product not complying with the Technical or Safety standards in the country in which it is used.
 - b) Repairs by unauthorized personnel or by the Customer himself.
 - c) Accidental events, lightning, floods, fires, incorrect ventilation or other causes not attributable to ELSIST.
 - d) Defects of the equipment or equipment to which the product was connected.
5. This warranty does not affect the buyer's rights established by applicable national laws nor the Customer's rights to the reseller arising out of the sales contract.

Unless authorized by the manufacturer, reproduction of any part of this manual is prohibited. Our equipment, built with the utmost care and with selected components, is controlled by ELSIST Quality Services. However, if you notice any anomalies, please inform us by calling +39 02-950031 specifying serial number and model of the device, which are printed on the identification plate at the rear side of the UPS. ELSIST Assistance Service is also available to collect requests, comments, suggestions, if any.

In case of failure:

Contact our Customer Service Center at +39 02 95 0031, and verify the UPS malfunction.

If the products returned to NAICON were OPERATING or if they were delivered without our permission or for out-of-warranty products, they will be returned to the customer by charging a cost that will depend on the country where will be shipped.

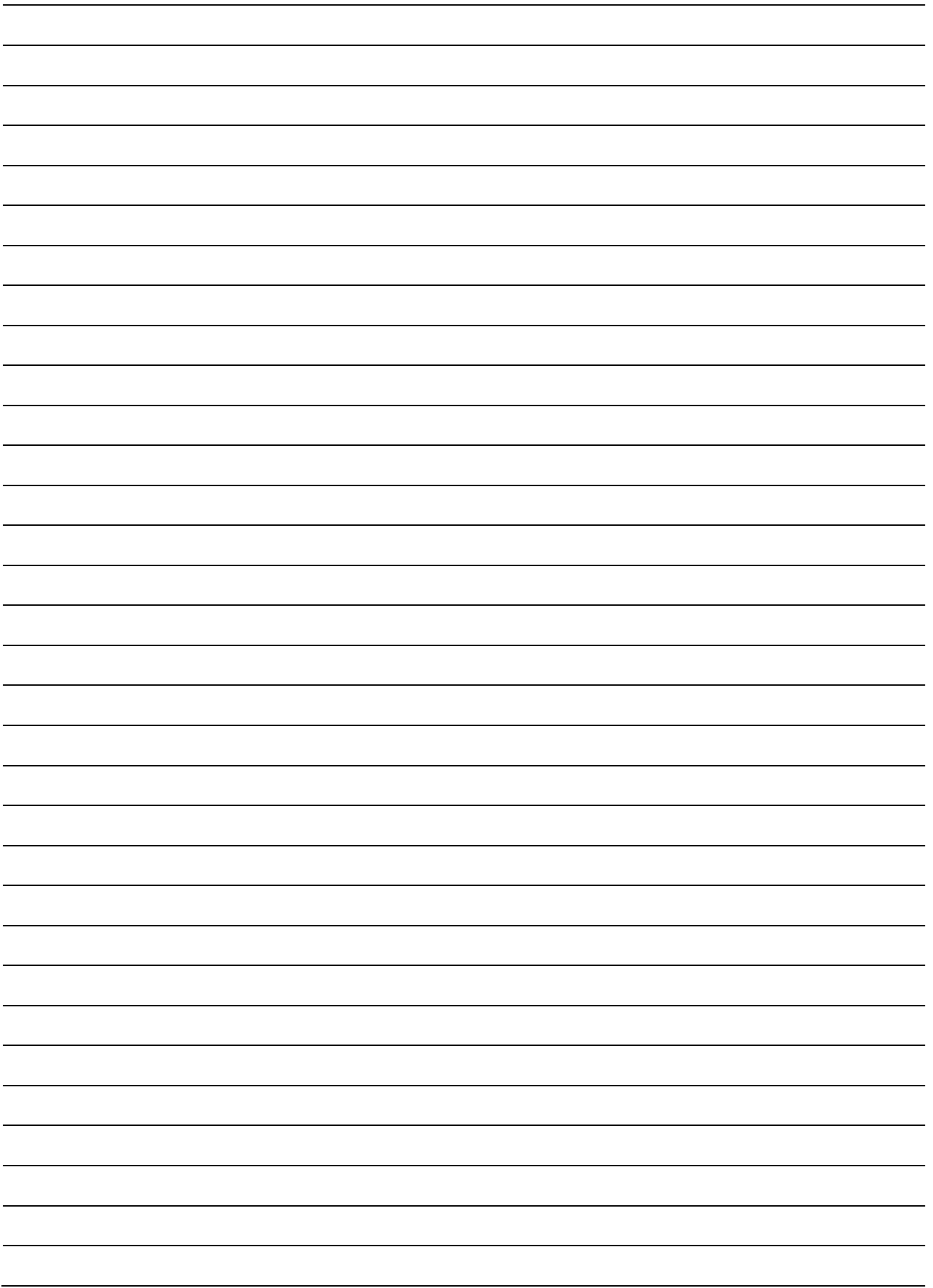



 **NaiconGroup**

Naicon srl Via il Caravaggio, 25 Trecella
I-20060 Pozzuolo Martesana - Milano (Italy)
Tel. +39 02 95.003.1 Fax +39 02 95.003.313
www.naicon.com e-mail: naicon@naicon.com